



UDC 631.314:316.4

RESULTS OF EXPERIMENTAL STUDIES CONDUCTED TO SUBSTANTIATE THE PARAMETERS OF AN IMPROVED MOLA-LEVELER WITH A WEDGE-SHAPED ROLLER

<https://doi.org/10.5281/zenodo.20388530>

A. Tukhtakuziev¹M.M. Ergashev¹I.A. Akbarov¹I.A. Khudoyberdiev²

¹*Scientific Research Institute of Agricultural Mechanization.*

²*Gulistan State University.*

Abstract. *The article presents the results of experimental studies conducted to substantiate the parameters of a mola-leveler with a wedge-shaped roller. Based on these results, it was established that, in order for the mola-leveler with a wedge-shaped roller to ensure the required level of work quality with low energy consumption, the diameter of its roller should be 335-370 mm, the sharpening angle should be 73-86°, and the vertical load should be 2.02-2.14 kN/m.*

Keywords: *improved mola-leveler with a wedge-shaped roller, leveler, wedge-shaped roller, experimental studies, soil crumbling quality, soil density, specific draft resistance, laboratory-field unit, travel speed, regularities of changes in performance indicators.*

INTRODUCTION

The main task in preparing land for sowing consists in leveling the surface of fields, compacting it to the required level, and crushing the large clods in it in order to form a fine soil layer. At present, for this purpose in Uzbekistan the MV-6.0, MV-6.5, as well as other mola-levelers available on farms, are widely used. However, because the compacting parts of the existing mola-levelers interact with the soil by sliding, considerable accumulation of soil in front of them and adhesion of soil and plant residues to

their working surfaces are observed. As a result, the work quality of the mola-leveler deteriorates and its draft resistance increases [1-2].

The studies we conducted showed that the indicated shortcomings of the existing mola-levelers can be eliminated by replacing their compacting part, which has a working surface that operates on the soil by sliding, with a rotating wedge-shaped roller. As a result, the considerable accumulation of soil in front of the compacting parts of the mola-leveler and adhesion to their working



surfaces are eliminated; due to this, the work quality of the mola-leveler improves, its productivity increases, and draft resistance and fuel consumption decrease. Based on the above, a mounted mola-leveler whose compacting part consists of a wedge-shaped roller was developed, and theoretical and experimental studies were conducted to substantiate its parameters.

Materials and Methods. The mola-leveler with a wedge-shaped roller consists of a frame 1 equipped with a hitching device (see Figure 1), a leveling working part (hereinafter referred to as the leveler) 2, and a wedge-shaped roller 3. When it moves across the field, the

leveler levels the surface of the worked field, while the wedge-shaped roller rotates around its axis, compacts the leveled surface, and crushes the clods in it.

This article presents the results of multifactor experiments conducted to determine the values of the diameter of the wedge-shaped roller of the mola-leveler with a wedge-shaped roller, the sharpening angle of the wedge-shaped part of the roller, the specific vertical load applied to the roller, and the travel speed that ensure the required work quality with low energy consumption. In this case, the experiments were conducted using the Hartley-4 design [3-5].

In conducting the multifactor experiments, the evaluation criteria were taken to be the degree of soil crumbling, that is, the content of soil fractions smaller than 25 mm, the soil density in the 5-15 cm layer, and the specific draft resistance of the improved roller mola-leveler. These indicators were determined according to the regulatory documents O'z Dst 3412:2019 and O'z Dst 3193:2017 [6, 7].

The data obtained in the experiments were processed using the "Regression Analyses" program developed in the experimental-testing department of the institute [7]. In this process, the Cochran criterion was used to assess the homogeneity of variance, the Student criterion was used to assess

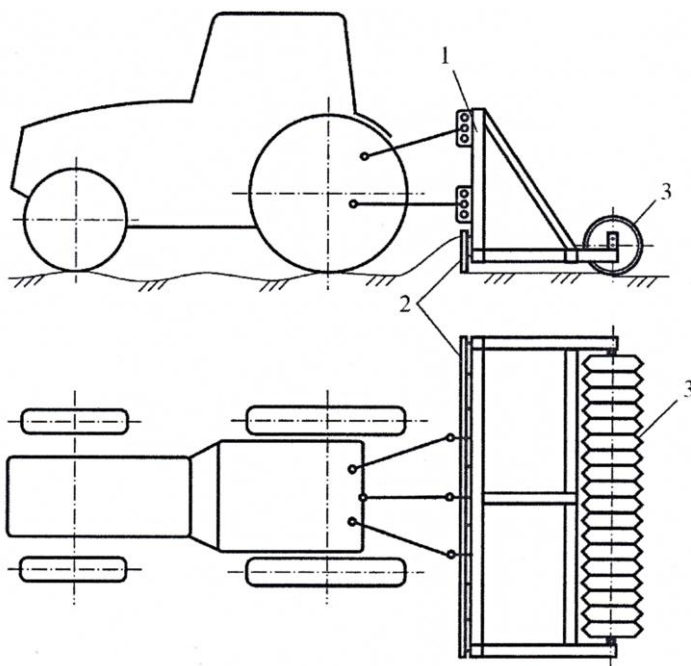

Figure 1. Structural scheme of the mola-leveler with a wedge-shaped roller

1 - frame; 2 - leveler; 3 - wedge-shaped roller



the values of the regression coefficients, and the Fisher criterion was used to assess the adequacy of the regression models.

Results and Discussion. The table below presents the factors, their designations, units of measurement, and levels of variation.

Intervals and Levels of Factor Variation

Factors and units of measurement	Factor				
	Coded designation	Variation interval	Levels		
			Lower (-1)	Basic (0)	Upper (+1)
1. Diameter of the wedge-shaped roller, mm	X ₁	50	300	350	400
2. Sharpening angle of the wedge-shaped part of the roller, °	X ₂	10	70	80	90
3. Specific vertical load applied to the roller, kN/m	X ₃	0.5	1.5	2.0	2.5
4. Travel speed, km/h	X ₄	1.5	6.0	7.5	9.0

The experimental results were processed in the specified order, and the following regression equations, which adequately describe the evaluation criteria, were obtained:

- for the degree of soil crumbling (%):

$$Y_1 = 88.1848 - 0.9387X_1 - 1.0497X_2 + 4.47X_3 + 2.1433X_4 + 0.7032X_1^2 + 0.3713X_1X_2 - 0.4579X_1X_3 + 0.13704X_1X_4 - 0.435X_2^2 - 0.6429X_2X_3 - 0.9296X_2X_4 - 0.7383X_3^2 + 0X_3X_4 - 0.8X_4^2; (1)$$

- for the soil density in the 5-15 cm layer (g/cm³):

$$Y_2 = 1.1335 - 0.059X_1 - 0.0583X_2 + 0.1051X_3 - 0.09083X_4 + 0.0359X_1^2 + 0.0037X_1X_2 - 0.0038X_1X_3 - 0.0062X_1X_4 - 0.0157X_2^2 + 0.0246X_2X_3 - 0.0213X_2X_4 - 0.0591X_3^2 - 0.02054X_3X_4 + 0.01243X_4^2; (2)$$

- for the specific draft resistance of the improved roller mola-leveler (kN):

$$Y_3 = 2.0851 - 0.0927X_1 + 0.1450X_2 + 0.1800X_3 + 0.0350X_4 + 0.04852X_1^2 + 0.0575X_1X_2 + 0.0825X_1X_3 + 0.010575X_1X_4 - 0.01472X_2^2 - 0.0525X_2X_3 - 0.010725X_2X_4 + 0.0618X_3^2 + 0.01275X_3X_4 + 0.010968X_4^2. (3)$$

Analysis of regression equations (1)-(3) shows that all factors had a significant effect on the evaluation criteria.

With a change in the diameter of the wedge-shaped roller, that is, with an increase in factor X₁, all criteria - namely the degree of soil crumbling, density, and draft resistance - first decreased and then almost did not change.

With an increase in factor X₂, that is, the sharpening angle of the wedge-shaped part of the roller, criteria Y₁ and Y₂ decreased, while criterion Y₃ increased according to the law of a convex parabola.

With an increase in factor X₃, criteria Y₁ and Y₂ increased according to the law of a convex parabola, while



criterion Y_3 increased according to the law of a concave parabola.

Regression equations (1)-(3) were solved under the conditions that criterion Y_1 should be greater than 85%, criterion Y_2 should be within the range of 1.10-1.20 g/cm³, and criterion Y_3 should have a minimum value. It was determined that, at travel speeds of 6.0-9.0 km/h, the diameter of the roller of the developed mola-leveler with a wedge-shaped roller should be 335-370 mm, the sharpening angle of the disc installed on the roller should be 73-85°, and the vertical load applied to it should be within the range of 2.02-2.14 kN/m.

CONCLUSION

In order to ensure the required degree of soil crumbling and compaction with low energy consumption, the diameter of the roller of the mola-leveler with a wedge-shaped roller should be 335-370 mm. In order for the aggregate to ensure the required level of soil crumbling and compaction with low energy consumption at travel speeds of 6.0-9.0 km/h, the diameter of the roller of the mola-leveler with a wedge-shaped roller should be 335-370 mm, its sharpening angle should be 73-86°, and the vertical load applied to it should be within the range of 2.02-2.14 kN/m.

REFERENCES:

1. Tukhtakuziev, A., Akbarov, I. Results of experimental studies conducted to substantiate the parameters of a roller mola-leveler. Innovative solutions for creating highly efficient agricultural machines and increasing the level of use of technical means International Scientific and Technical Conference. – Gulbahor, 2022. pp. 145-148.
2. Ergashev M.M Mukimov Z.A. (2026). SUBSTANTIATION OF THE PARAMETERS OF THE DEEP LOOSENER–FURROW OPENER IMPLEMENT FOR A TREE SEEDLING PLANTING MACHINE [Data set]. Zenodo. <https://doi.org/10.5281/zenodo.20096333>
3. Augambaev, M., Ivanov, A. Z., Terekhov, Yu. I. Fundamentals of Planning a Scientific Research Experiment. – Tashkent: O‘qituvchi, 1993. – 336 p.
4. Spirin, N. A., Lavrov, V. V. Methods of Planning and Processing the Results of an Engineering Experiment. – Yekaterinburg: Ural State Technical University - UPI, 2004. – 258 p.
5. Tukhtakuziev, A., Khudjaev, M., Ergashev, M., Akbarov, I., Abdubannopov, A. Determining the parameters of a disk digger for a machine planting fruit tree seedlings. Kexue Tongbao/Chinese Science Bulletin. 2026. Vol. 71, Issue 03, pp. 5689-5701. DOI: 03.1893/Csb.30.04.2026.01.
6. O‘zDst 3412:2019 “Testing of agricultural machinery. Machines and implements for soil surface tillage. Test program and methods”. – Tashkent, 2001. – 54 p.



7. O‘zDst 3193:2017 “Testing of agricultural machinery. Method for energy assessment of machines. Technical specifications.”. – Tashkent, 2001. 18 p.